



# Vigiline

Connected level regulator  
for skimmer pools

Technical Sheet



Réf : PF10L111/ PF10L110

# Table des matières

- 1. Technical specifications ..... 3
- 2. Package contents ..... 4
- 3. Description ..... 4
- 4. Compatible with the Vigipool universe ..... 5
  - 4.1. Bluetooth® and Wi-Fi control ..... 5
  - 4.2. Commissioning ..... 6
- 5. Wall mounting of the Vigiline ..... 9
- 6. Sensor installation ..... 10
- 7. Level sensor ..... 11
  - 7.1. Different states ..... 12
  - 7.2. Sensor commissioning ..... 13
  - 7.3. Battery Charger ..... 13
  - 7.4. Wintering ..... 16
  - 7.5. Updates ..... 17
- 8. Hydraulic system ..... 17
  - 8.1. Installation on piping ..... 17
- 9. Electrical installation ..... 18
  - 9.1. Power Supply for the Vigiline ..... 19
  - 9.2. Filling solenoid valve ..... 20
  - 9.3. Drain Solenoid Valve ..... 20
  - 9.4. Water meter ..... 22
- 10. Operation ..... 23
  - 10.1. Multicolor Vigiline indicator light ..... 23
  - 10.2. Multicolor level sensor indicator light ..... 24
  - 10.3. Multicolored charging indicator ..... 24
- 11. Resetting the Vigiline ..... 25
- 12. Resetting the level sensor ..... 25

Declaration of conformity .....



**Avertissement**

Read these instructions carefully before installing, commissioning and using this product.

# 1. Technical specifications

Power Supply	230V AC - 50Hz
Weight	Only the Vigiline : 100g
Installation	Wall mounted
Protection rating	IP-40 : The control panel IP-68 : Level control sensor
Output	230V AC power supply input (pre-wired) 1 230V AC Output - For filling solenoid valve 1 NO contact Output - For drain solenoid valve ( in option) 1 "Meter" output: Connecting the smart water meter 1 Output "IP": Wired connection of the pump shut-off device to non-Vigipool control boxes
Level sensor	Available colors of sensors: White (RAL 9003) : PF10L110 / Anthracite (RAL 7016) : PF10L111  Sensor's dimensions: 118mm x 76mm  Sensor's support dimensions: 120mm x 40mm

## 2. Package contents

<p>1 Vigiline package control panel</p> <p>1 brass 1/2" filling solenoid valve, 230V AC</p> <p>1 Pulse water meter: <b>Install with the face facing upwards</b></p> <p>1 pair of 1/2" connectors for the water meter</p> <p>1 Level sensor</p> <p>1 Level control sensor bracket</p> <p>1 Vigiline wall mount</p> <p>1 Induction charger for the level sensor</p>	<p>1 brass screen filter for 1/2" solenoid valve (max. pressure 4 bar)</p> <p>1 Digital notice</p> <p>11 Telescopic Magnetic Stylus: <b>MPCP0450</b></p>
---	--

## 3. Description

Vigiline is a level regulator for skimmer pools connected to Vigipool and supplied with a wireless sensor. This sensor is a standalone wireless sensor for automatic level regulation in skimmer pools.

The level sensor has three sensors that enable it to differentiate between three levels. Level measurements are taken every 60 minutes (when the water level is correct) and every three minutes during filling or emptying. This sensor is equipped with a long-range, low-power Lora transmitter.



### Important

Please charge your level sensor before initial use.



### Astuce

Vigiline does not need to be used in conjunction with a Vigipool filtration control device.

---

## 4. Compatible with the Vigipool universe

Vigiline is compatible with many devices integrated into the Vigipool universe. The Vigipool universe brings together many interconnected water maintenance and treatment devices that can be controlled by a single application: **Vigipool**.

The devices exchange the various measured information and their actions with each other wirelessly via a proprietary connection between the devices. Various devices are available (electrical filtration box, LED control, pH regulation, connected pH/ORP analyzer, remote touchscreen display, etc.).



### 4.1. Bluetooth® and Wi-Fi control

The Vigiline has a Bluetooth® and Wi-Fi transmitter, allowing you to control your device via smartphone or tablet. To control the Vigiline, you need an iOS (Apple®) or Android smartphone or tablet equipped with Bluetooth® Low Energy (v4.x) or Wi-Fi 802.11 b/n/g. Other operating systems (Windows Phone®, etc.) or devices that do not meet the above requirements **are not supported**.

In the case of a Wi-Fi connection, you will need to enter the local Wi-Fi details (SSID and password) and create a Vigipool account in order to connect your Vigiline to the Wi-Fi router and thus control your Vigipool device via the local Wi-Fi and remotely. (see dedicated "Vigipool Universe" leaflet attached)



#### Astuce

With Bluetooth, only one phone/tablet can be connected to the box at a time. To connect with another device, you must first **disconnect from the previous one**.

It is possible to automatically update the software embedded in the device. To do this, it must be connected to WiFi or to another Vigipool device that is itself connected to WiFi. If you only use the device via Bluetooth, you can create an access point from your phone in order to temporarily connect the device and update its software if necessary.

---

### 4.1.1. Bluetooth® pairing

When connecting for the first time (via Bluetooth), after selecting your device from the list, in order to pair your smartphone with the Vigiline, you must bring the smartphone close to the device until it makes contact, or press button A once when prompted by the app and when the A indicator light flashes blue rapidly.



Astuce

Pairing can only be done via the Vigipool app. Do not attempt to pair via your smartphone's Bluetooth settings.

## 4.2. Commissioning

### 4.2.1. Powering up

The Vigiline is started up by connecting it to a permanent 230V AC power supply.

When starting up, the multicolored indicator light A on the front panel flashes while the device is starting up.



## 4.2.2. Thermal Protection

### 4.2.2.1. Thermal circuit breaker



If the current is too high, the thermal circuit breaker will trip. Check the installation of the projectors before resetting it by pressing on it.

---

### 4.2.3. Choice of Vigipool “central” unit



#### Astuce

Please refer to the attached “Vigipool Universe” leaflet for further information.

---

At the end of the initialization phase (Blue - White - Red sequence), the multicolor indicator light A flashes white. This corresponds to the selection of the device that will perform the Vigipool “control center” function (see the attached “Vigipool Universe” leaflet):

- If the installation is equipped with several Univers Vigipool-compatible devices
  - If a device is already configured as the Vigipool “Control Center,” press the button on the Vigipool “control center” device if it has been powered on for more than one minute. (If it has been powered up for less than a minute, there is no need to press the button). Your Vigiline will then connect to the Vigipool “Control Center”: it will stop flashing white and switch to normal operating mode.
  - And if no other device is already configured as the Vigipool “control center,” turn on all devices and press the button on the device you want to use as the Vigipool “control center.” The other products will then connect to the device you have validated as the Vigipool “control center,” stop flashing white, and switch to normal operating mode.



#### Astuce

If you wish to change the Vigipool “control center” selection, you must reset the system (see “Resetting”).

---

### 4.2.4. iOS/Android applications

To download the Vigipool app, click here or scan the QR code below. You can also search for Vigipool in the App Store or Play Store search engine:



## 5. Wall mounting of the Vigiline

### The Vigiline

- can be installed outdoors, but must be protected from rain, cleaning jets or sprinklers, and UV rays (sun).
- resistant to water splashes but must not be placed in a location that could be flooded
- must be placed on a flat, stable surface and secured to the wall using the wall bracket and the dowels and screws provided:

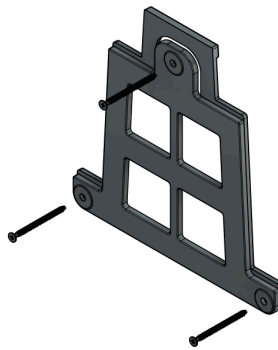

## 6. Sensor installation

The level sensor

- Installs in the skimmer passageway
- The support must be glued into the skimmer.
- Must be placed on its adhesive backing in the skimmer.

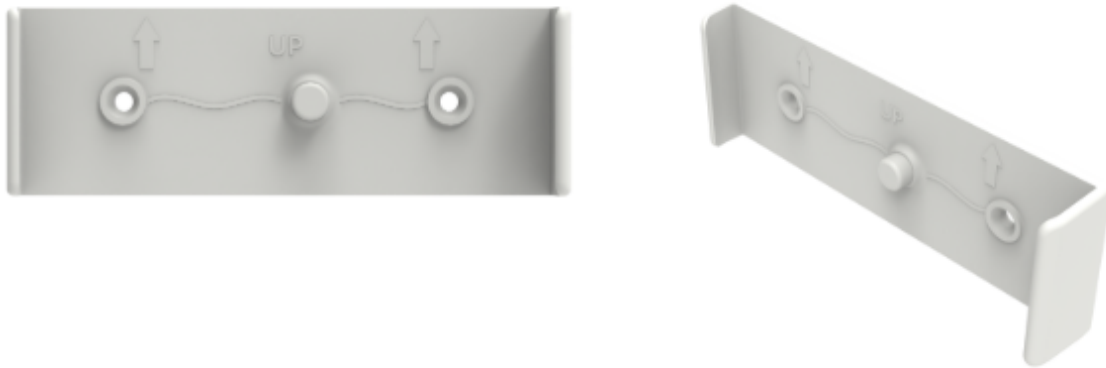

### Avertissement

Follow the direction of the arrows when gluing the backing.

Adhesive for fixing advisor: Axon MS3000 PRO

---

## 7. Level sensor



Standalone wireless sensor for automatic water level control in skimmer pools. Powered by a rechargeable battery via induction. (Charger included in the package).

3-level water detection

- Overflow (Drain)
- Correct (End of filling)
- Water shortage (Filling)

	<p>X:Sensor LEDs Y:Charging status LEDs Z:Hollow on the back of the sensor</p>
--	--



### Avertissement

The level measurement is performed every 60 minutes when the water level is correct and every 3 minutes during filling or emptying. The water level measurement is only performed when the sensor is in place in its holder.

## 7.1. Different states

### 7.1.1. Level Water shortage

When the water in your pool falls below the level **Water shortage**, filling is triggered until the level rises above the **correct level**.

Below this level, the pump and refill are activated. If you have the Tild Vp connected box, there is no need to connect the IP terminals of the Vigiline box to terminals C and D of the Tild Vp.

If you have a CCEI filtration control panel that is not connected, it is mandatory to connect these terminals. The pump lock will prevent your filtration pump from operating without water.

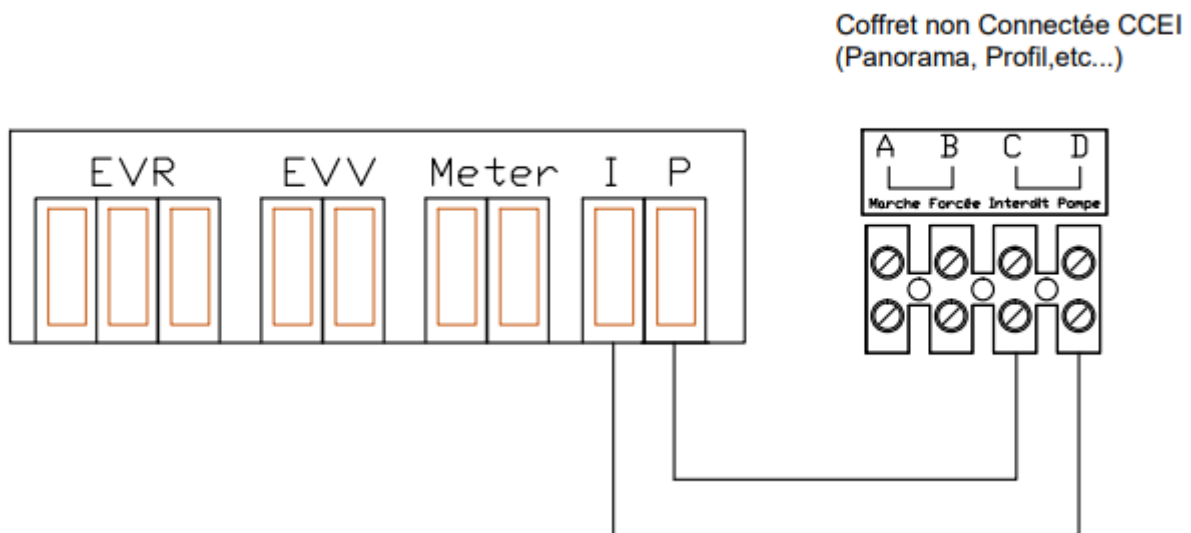

#### Important

In this mode, the sensor measures the water level every 3 minutes. This will prevent any overflow.

### 7.1.2. Correct Level

As soon as the sensor detects the correct water level, it stops filling. In this state, the sensor goes into standby mode and takes new measurements every 60 minutes.



### Important

In this state, the sensor measures the water level every 3 minutes. This will prevent any overflow.



## 7.1.3. Overflow Level

As soon as the water level reaches the overflow point, Vigiline activates the drain relay (if present) and keeps it activated until the level drops below the correct level. If your installation does not have a drain circuit, then no action will be taken, except for a notification in your application.

## 7.2. Sensor commissioning

The sensor is activated after integrating and connecting Vigiline to your smartphone. To start the sensor, place it on its wireless charger in or near the technical room.

You will need to press the central device to integrate it into the Vigipool system of your installation.

## 7.3. Battery Charger

To recharge the sensor, place it on its induction charger. Two LEDs provide information on charging and battery status:

- Flashing Green: The sensor is correctly positioned on its charger and is charging.

- Solid green: 100% charged
- Flashing red: low battery

You can always check the battery status of your sensor in the Vigipool app.



Important

You will receive a notification when your sensor runs out of battery power.





Important

Please check that when you place the sensor on its charger, a message appears on the Vigipool app indicating that the sensor is charging, or that the green light is flashing.

---

## 7.4. Wintering

For winter storage, an option in the app allows you to put the sensor into Winter Mode. Simply place the sensor on its charger near the equipment room (within WiFi range) and check the Winter Mode box in the app.



### Important

It must be stored in a dry place. This mode also helps to preserve the battery over time.

When restarting the sensor, place it back on its charger and uncheck the winter mode.

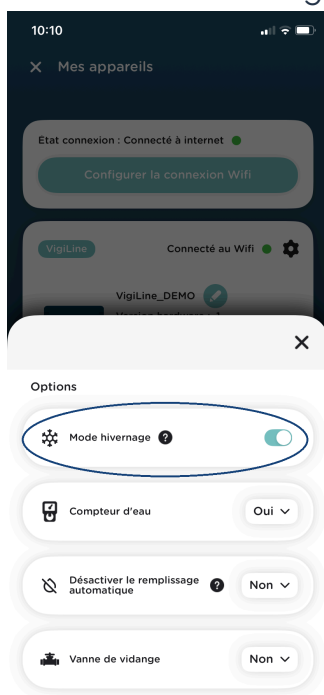

## 7.5. Updates

Sensor updates will be performed automatically by the application. When the application proposes a sensor update, it is necessary to place the sensor on its charger within range of the technical room's Wi-Fi in order to perform the update.

## 8. Hydraulic system

### 8.1. Installation on piping

A: Water inlet valve

B: Connected water meter

C: Filter

D: Fill solenoid valve

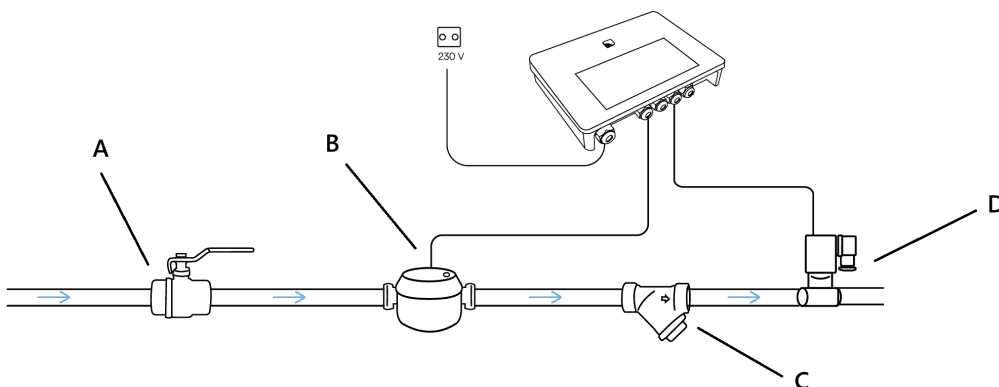

## 9. Electrical installation

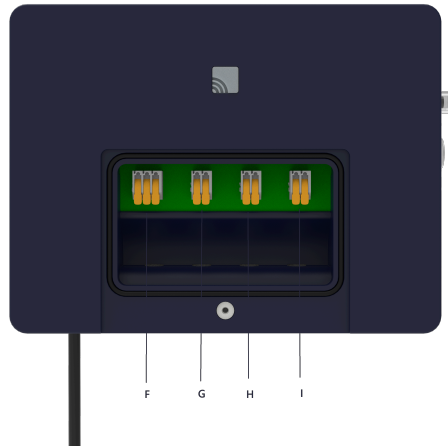

<p>F: EVR</p>	<p>230V AC power supply for the fill solenoid valve</p> <p>N:Blue Wire</p> <p>L: Brown wire</p> <p>Terre: Earth wire</p>
<p>G: EVV</p>	<p>Dry contact for solenoid valve or drain pump (optional)</p>
<p>H: Meter</p>	<p>Installing the pulse water meter</p>
<p>IP:Branchement Interdit Pompe</p>	<p>Wired connection of a “pump disabled” contact to an unconnected control panel (Panorama, Profil, etc.)</p> <p>All of our CCEI control panels feature an ABCD terminal block for connecting the forced-on contact and the “Pump Off” contact.</p>

## 9.1. Power Supply for the Vigiline

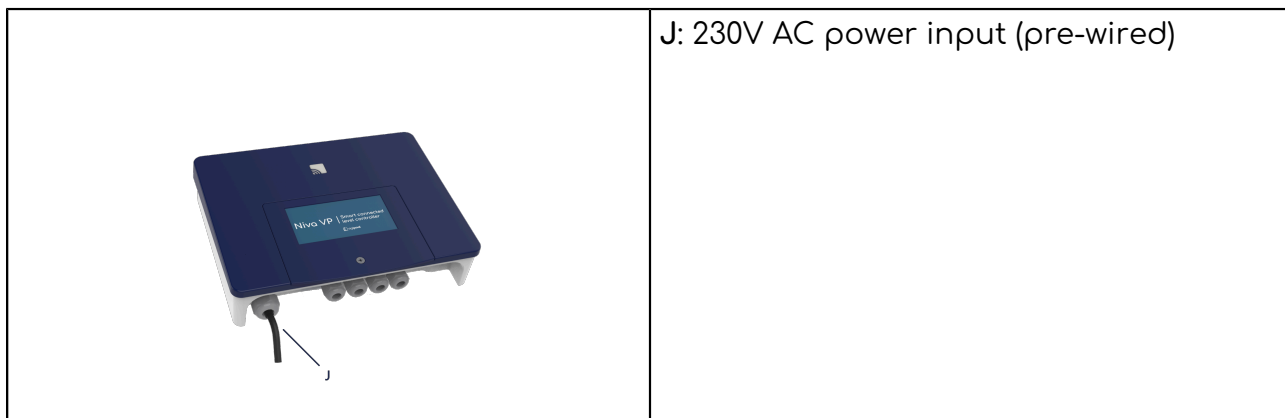

## 9.2. Filling solenoid valve

The filling solenoid valve is installed after the water meter and the strainer. It is connected directly to the Vigiline at the N/L/Ground terminal block.



### Important

The arrow marked on the solenoid valve body must point in the direction of water flow when the valve is installed.

---

## 9.3. Drain Solenoid Valve

The Vigiline provides a dry contact free of any potential for a drain pump.

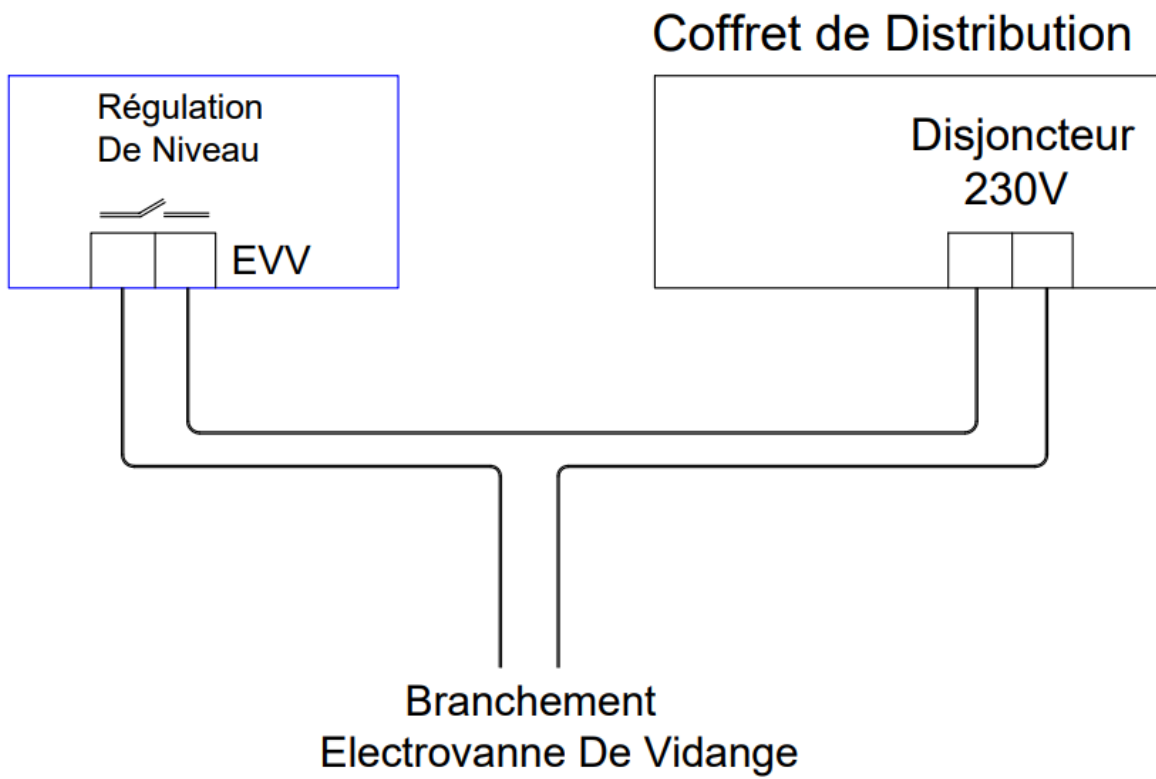

Important

The drain solenoid valve is not included in the package. It is an optional extra.

## 9.4. Water meter

This pulse meter allows you to monitor your pool's water consumption online. It also detects leaks in the water system in the equipment room, on the screen filter, and on the solenoid valve.

If the solenoid valve is supposed to be closed and there is a leak in the solenoid valve or screen filter, the water meter will continue to run, alerting the user via the Vigipool app.



### Important

For the meter to function properly, it must be installed with the face facing upwards.

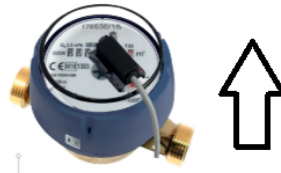

## 10. Operation

### 10.1. Multicolor Vigiline indicator light



Depending on its status, the multicolored indicator light A can have different meanings:

Blue-White-Red Sequence	Device startup sequence: This sequence is performed when the device is powered on.
Flashing white	Waiting for the Vigipool "Centrale" unit to be selected. See section 6.2.
Solid blue	A smartphone is connected to the Vigiline via Bluetooth
Blue flashing (slow)	The Vigiline is set to "Control Center" mode in Vigipool, and Wi-Fi is not configured: Waiting for a Bluetooth connection.
Blue flashing (rapid)	Bluetooth pairing in progress. See section 4.1.1.
Solid green	The Vigiline is connected to Wi-Fi or its Vigipool "Control Unit."
Flashing green	The Vigiline is configured in Vigipool "Control Center" mode and is ready to connect to new Vigipool devices. This is normal during the first 5 minutes after power-up or 5 minutes after pressing the button. See section 6.2.
Flashing purple	Firmware update in progress.
Red / Green flashing alternately	If the Vigiline is configured as a Vigipool "Control Center": Unable to connect to Wi-Fi. Check the information you entered and/or the Wi-Fi network coverage.

	If not: Unable to connect to the Vigipool "Control Center"
--	--

## 10.2. Multicolor level sensor indicator light

Blue-White-Red Sequence	Sensor startup sequence: This sequence is performed when the power is turned on.
Solid green	The sensor is connected to the central device.
Flashing Green	The sensor is charging
Solid Green	The sensor is 100% charged.

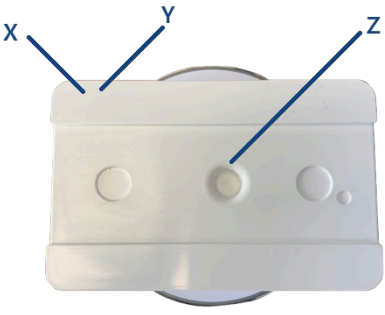
	<p>X:Sensor LEDs</p> <p>Y:Charging status LEDs</p> <p>Z:Hollow on the back of the sensor</p>
--	--

## 10.3. Multicolored charging indicator

Steady green LED Y	The sensor is 100% charged
Flashing Green LED Y	The sensor is charging

## 11. Resetting the Vigiline

It may be necessary to perform a reset to restore the Vigiline to its factory settings.

To do this:

1. Turn off the device using the ON/OFF switch and wait for about ten seconds.
2. Press and hold button (A) on the Vigiline.
3. Turn on the device while holding down the button.
4. Wait until the multicolored light flashes rapidly in red,
5. Release the bouton. All settings are reset to factory defaults.



### Avertissement

Performing a reset will erase all settings stored in memory (WiFi configuration, pairing of phones and other Vigipool Universe devices, etc.). It is therefore necessary to repeat the commissioning procedure after performing a reset.

---

## 12. Resetting the level sensor

It may be necessary to perform a reset in order to restore the factory settings.

To do this:

1. Take the magnetic telescopic stylus provided in the packaging.
2. Remove the sensor from its holder.
3. Wait 5 seconds for the red LED on the sensor to light up.
4. Move the stylus (the magnetic part) back and forth five times in the hollow on the back.
5. Wait until the LED flashes green.
6. All settings are reset to factory defaults.



### Avertissement

Performing a reset will erase all settings stored in memory (WiFi configuration, pairing of phones and other Vigipool Universe devices, etc.). It is therefore necessary to repeat the commissioning procedure after performing a reset.

---

CCEI declares that the product Vigiline meets the safety and electromagnetic compatibility requirements of European Directives 2014/35/EU and 2014/30/EU EU and the Radio Equipment Directive 2014/53/EU.



Emmanuel Baret  
Marseille, on 15/03/2025

Distributor's stamp

*Date of sale:* ..... *Batch N°:* .....