



# Phileo VP & Phileo POD VP

Automatic and connected  
pH regulation

OPERATING INSTRUCTIONS



PF10J050 - PF10J051

---

# Table of Contents

1. Technical specifications .....	3
2. Pack contents .....	4
3. Description .....	4
3.1. Bluetooth® and Wifi control .....	4
3.2. iOS / Android applications .....	5
3.3. pH regulation .....	5
4. Installing the Phileo VP & Phileo POD VP .....	6
4.1. Wall mounting .....	6
4.2. Hydraulic connection .....	8
4.3. Connecting the sensor <b>and flow detector</b> .....	13
4.4. Connection to electricity .....	13
5. Operation .....	14
5.1. Control interface .....	14
5.2. Configuration .....	14
6. Appliance operation .....	19
6.1. Data timer and injection not active: .....	19
6.2. Selecting of set-point value .....	20
6.3. Measured value display .....	20
7. Reset to zero .....	21
8. Sensormaintenance .....	21

Declaration of conformity .....



Warning

Read these instructions carefully before installing, commissioning and using this product.

---

## 1. Technical specifications

Dimensions	260 x 180 x 80
Power supply voltage	230 V AC 50Hz
Power consumption	10W
Weight	700 g (Pump only)
Protection rating	IP-54
<b>pH regulation</b>	Measurement using a combined electrode - +/- 0.1 pH = 5 to pH = 9 pH 6.86 (2-point calibration using the app)
Measurement range	
Calibration	
<b>Dosing pump</b>	Peristaltic
Flow rate	from 0 to 1.2 l/h
<b>Zeliapod dimensions</b>	185 mm (length)
Only Phileo POD VP	Connection Ø 50mm
Bluetooth®	Low Energy (v4.x)
Wifi	802.11 b/g/and "dual band" (2.4 Ghz only)

## 2. Pack contents

1 Box Phileo VP & Phileo POD VP	1 Injection kit (injector, strainer, tube)
1 Flow detector	1 calibration container
1 pH sensor + sensor holder	1 pH 6.86 calibration solution bag
1 Technical manual (this document)	2 #50 1/2" pipe saddle (if Phileo VP)
1 "Vigipool Universe" leaflet	1 #50 3/4" pipe saddle + 3/4" M nipple (if Phileo VP)
1 wall support + 2 screws and 2 wall plugs	1 ZeliaPod measuring chamber + union fittings + 3/4" M nipple (if Phileo POD VP)
1 teflon roll	

## 3. Description

- Automatic pH regulation using a set point value
- RGB Back-lit dosing pump
- User friendly interface: 1 selection button + 5 indicator lights
- User friendly smartphone app
- Wifi and Bluetooth connection
- Easier installation using the ZeliaPOd measuring and injection chamber (if Phileo POD VP)
- Compatible with the Vigipool connected environment

### 3.1. Bluetooth® and Wifi control

The Phileo VP & Phileo POD VP control box has an embedded Bluetooth® and Wifi transmitter used to control your appliance from a smartphone or tablet. To be able to control the Phileo VP & Phileo POD VP, you need an iOs (Apple®) or Android smartphone or tablet running Bluetooth® Low Energy (v4.x) or Wifi 802.11 b/n/g. Other oper-

---

ating systems (Windows Phone®,...) or devices not running the above-mentioned prerequisites **are not supported**.

For a Wifi connection, the local Wifi details (SSID and password) need to be entered and a Vigipool account created to connect your **Phileo VP & Phileo POD VP** to the Wifi router and control the **Phileo VP & Phileo POD VP** using local Wifi and remotely (see "Vigipool Universe" leaflet).

## 3.2. iOS / Android applications

To download the Vigipool application, scan the QR CODE below. You can also search for Vigipool in the App Store or Play Store search engine:



### Tip

With Bluetooth, only one phone/tablet can be connected to the box at a time. To connect with another device, you must first disconnect.

To enable the Bluetooth pairing, bring the phone/tablet up to the unit's contact when requested by the app, or press the button on the device.

It is possible to automatically update the software embedded in the device. To do this, it must be connected to WiFi or to another Vigipool device that is itself connected to WiFi. If you only use the device via Bluetooth, it is possible to create an access point from your phone in order to temporarily connect the device and update its software if necessary.

---

## 3.3. pH regulation

The pH, or potential Hydrogen, is a highly important parameter for water treatment. It has a strong influence on the efficiency of disinfectants. The pH, or potential Hydrogen, measures the acidity of the water. Its value is between 0 and 14. A solution with a pH of 7 is neutral. If the pH is below 7 the solution is acid and if it is above the solution is called basic or alkaline.

For the comfort of bathers, effective treatment and reliability of the installation, the swimming pool water pH must be kept at about 7. A pH of between 6.8 and 7.8 is gen-

erally considered to be correct. Water which is too acid ( $\text{pH} < 6.8$ ) is aggressive to the mucous membranes, causes metal parts to corrode and may damage plastics (liners). Water which is too alkaline ( $\text{pH} > 7.8$ ) may also be aggressive (caustic) and considerably reduce the effectiveness of the chlorine.

Users can configure the Phileo VP & Phileo POD VP for pH- mode or pH+ mode. In pH- mode, the Phileo VP & Phileo POD VP injects PHminus to lower the pool pH and in pH+ mode, it injects PH plus to raise the pool pH.

In order to avoid possible measurement errors, it is recommended to check the sensor calibration once per month. To do this, just follow the instructions in the CALIBRATION section.



#### Warning

The disinfectants and pH correctors used for pools can have an adverse effect on health and the environment.

*These chemicals must be handled with care and stored in an adapted location.*

## 4. Installing the Phileo VP & Phileo POD VP

### 4.1. Wall mounting



#### Tip

For safety reasons, and in accordance with the French NF C15-100 standard, the Phileo VP & Phileo POD VP control box must be installed

- either at over 3.50 m from the pool edge. This distance takes into account the distance around obstacles. If the Phileo VP & Phileo POD VP control box is installed behind a wall, the distance will include the length of the path taken to move around the wall to reach the box.
- or in an in-ground space in the immediate vicinity of the swimming pool. In this case the space must be accessible via a hatch which requires a tool to open it.

### The automatic controller **Phileo VP**

- should not be installed outdoors, it should be protected from rain, cleaning or watering jets, and UV radiation (sun).
- resistant to water splashes but **should not be placed in a flood risk area.**
- must be placed on a safe and stable surface and fixed to the wall using the wall support and the supplied plugs and screws:

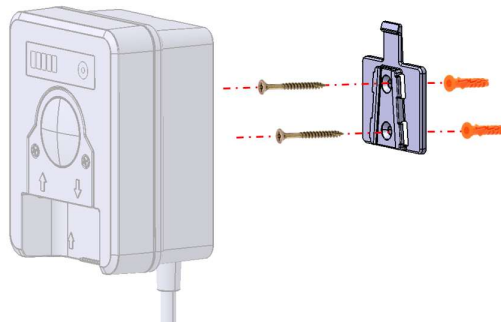

## 4.2. Hydraulic connection

The Phileo VP model is shipped with 3 pipe saddles to install the accessories required to correct operation.

To make installation easier, the Phileo POD VP model is shipped with the ZeliaPod measuring and injection chamber. This measuring chamber makes it possible to limit the number of drill holes in the piping and to centralise data.

### 4.2.1. Injector installation - Phileo VP model

The injector is used to inject the swimming pool with the required amount of product. It is imperative that the injector be placed after the sensors (pH and RedOx) and as close as possible to the backflow into the pool.

TEFLON must be used to screw the injector to the ½" pipe saddle.

The tube is positioned on the injector by screwing the upper injector nut.

### 4.2.2. Flow detector installation - Phileo VP model

The detector is mounted on a ¾" pipe saddle. After having installed the pipe saddle, and making sure no protrusions (on the pipe drilling) can block the movement of the detector, screw the ¾" nipple to the saddle using Teflon, then gently screw the detector to the other end of the nipple. Whether the flow detector is installed vertically or horizontally, the arrow engraved on the detector must point in the water flow direction.

#### 4.2.2.1. Sensor installation - Phileo VP model

The sensor is installed on the outlet pipe using a pipe saddle into which the sensor holder is screwed.

### 4.2.3. ZeliaPod hydraulic installation - POD VP model only

ZeliaPod installs on a diameter 50mm pipe using the supplied union fittings. It is installed downstream of filtration (after the filter) and must be placed horizontally on a section of pipe that is always pressurised relative to the pool water level, this is to make sure that there is always water in the Zelia Pod and that the sensors are always in water.

Prefer using a by-pass (mandatory in excess of 15m<sup>3</sup>/hour) so that the flow can be controlled, and to be able to remove it without stopping filtering.



Tip

During installation and use, make sure the **Zelia Pod** is pressurised relative to the pool water level, to make sure it is always full of water and free of air. If this were not the case and air is present inside the measurement chamber, the sensor readings may not be correct.

When installing, fit the sensors by pushing them gently all the way into their housing, lift 3-4 mm and tighten the sensor holder nut.

---

#### 4.2.4. Installation diagram without Zelia Pod - VP Model

The flow detector (D) is placed on the same section of pipe as the other supplied elements. The pH sensor (B) must be placed after the filter at a minimum distance of 60 cm from any other measuring appliances, and as far away as possible from the pH injector (E), installed downstream and placed as close as possible to the pool backflow.

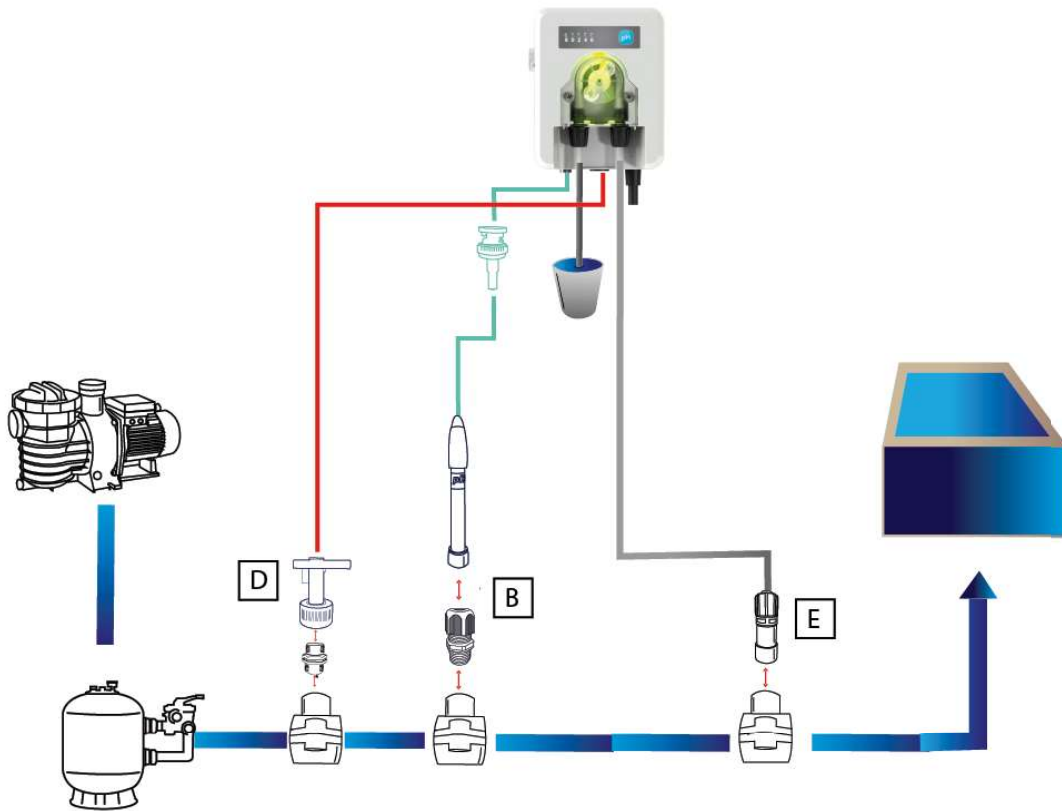

#### 4.2.5. Accessory position

Use the photo below to see where to position the different elements. To screw in the injector (E or F), use the provided flat seal to make the assembly watertight. The use of Teflon tape on the sensor holder (B or C) threading is recommended.



- A. Ground rod
- B. Ph sensor housing
- C. Redox sensor housing (optional)
- D. Flow detector
- E. pH injector housing
- F. Redox sensor housing (optional)

Use the supplied roll of Teflon tape when assembling the sensor holder and the supplied flat seal for the injector.

#### 4.2.6. Installation diagram with Zelia Pod - POD VP Model only

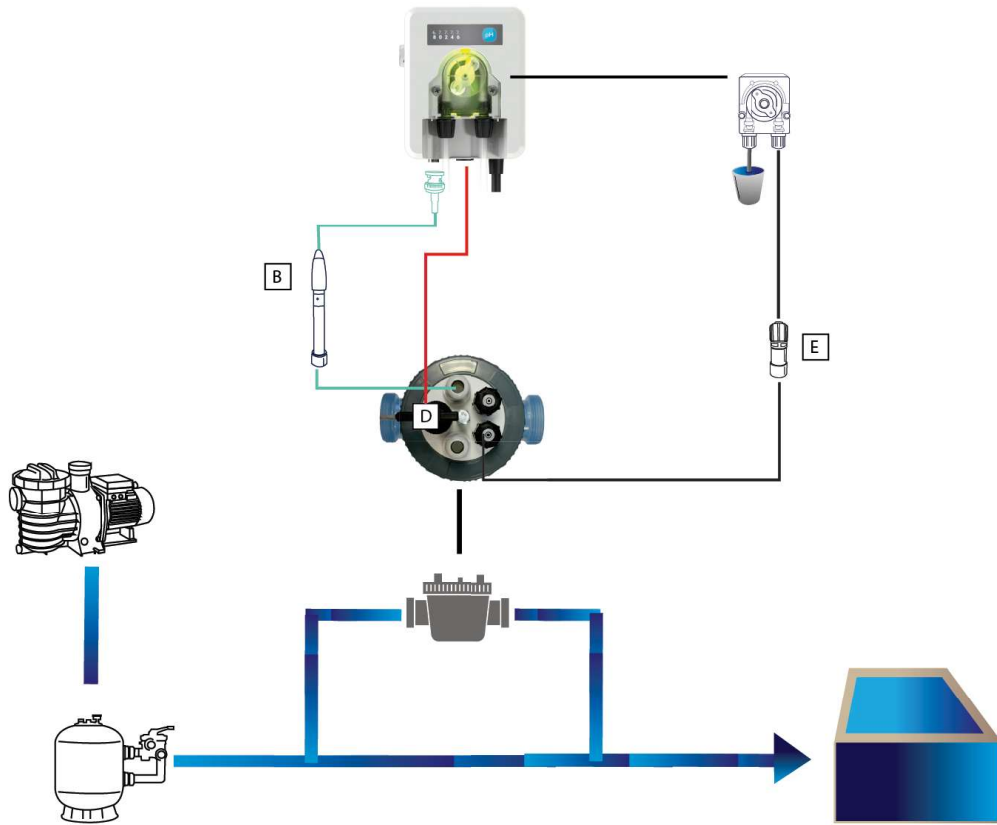

### 4.3. Connecting the sensor and flow detector



1. Power supply cable
2. pH sensor
3. Flow detector
4. Suction line
5. Injection line

### 4.4. Connection to electricity



#### Warning

Installation of this project involves a hazard of electric shocks. We strongly recommend you contract a professional installer. Incorrect installation puts you in danger and may irreversibly damage the product and the equipment connected to it.

The box is shipped with a power supply cable that can be connected to the mains in the technical room using a standard plug and socket (230V / 50 Hz). This socket must be protected by a 30mA ground fault circuit breaker in compliance with the NF C15-100 standard.



#### Caution

The appliance is fitted with a flow detector and must not be installed on a power supply line that is coupled to the filtering. This could cause the appliance to malfunction.

---

## 5. Operation

Phileo VP & Phileo POD VP can be configured using the pump interface or from the smartphone app available for iOS and Android. We encourage you to use the app which provides access to additional parameters, in particular for calibration.

### 5.1. Control interface

The interface is composed of a selection button (A), of 5 green light indicators (B) and a multi-colour LED (C) installed behind the dosing pump.



### 5.2. Configuration

#### 5.2.1. Powering up

The system is switched on using the luminous switch on the side of the automatic regulator.

When it is powered on, the light indicators on the front flash for several seconds until the appliance has started up.

(Start-up phase: flickering in the dark green indicators (B) and then different colours of the multi-colour LED (C))

---

## 5.2.2. Selecting the regulation mode



### Tip

- **pH-:** to inject a pH minus product and therefore lower the pool pH. The pump will start when the water pH is above the pH set point.
- **pH+:** to inject a pH plus product and therefore increase the pool pH. The pump will therefore start when the water pH is below the pH set point.

---

The pH system is set to pH-Minus by default. To switch to pH-Plus, please follow these steps after the initial installation:

1. Switch off the pH unit using the button on the side. Then hold down the pH button and switch the pH unit back on at the same time. Continue to hold down the (pH) button for **about 6 seconds**.
2. After about 10 seconds, the LED will light white continuously. As soon as the LED lights white, press the pH button immediately; the LED will then light turquoise (*cyan/blue*) (*pH Plus mode*).
3. After about 5 seconds, the LED will flash white. Briefly press the pH button to confirm the change. The pH Plus mode is now set.
4. Open the app and continue with the setup (please note that the Wi-Fi settings will need to be reconfigured)

## 5.2.3. Selecting the "central" Vigipool device



### Tip

- Please refer to the attached "Vigipool Universe" leaflet for more information.

---

Once the control mode has been selected, the multi-colour LED (C) flashes white. This corresponds to the chosen device that will operate the Vigipool "central" function (see "Vigipool Universe" leaflet attached):

- If only this device is installed in the system, press the selection button (A). The unit is now configured as a Vigipool "central" unit and you can add other units to the installation later.
- If the installation has several Vigipool Universe compatible devices
  - If a device is already configured as a Vigipool "central" device, press the button on the Vigipool "central" device if it has been powered for more than one minute. (If it

---

has been powered for less than one minute, it is not necessary to press the button). Your Phileo VP & Phileo POD VP then connects to the Vigipool "central" unit: it stops flashing in white and goes into normal operation mode.

- If no other device is configured as a Vigipool "central unit", turn on all the devices and press the button of the device you intend to use as Vigipool "central unit". The other products will connect to the device you have validated as Vigipool "central unit", stop flashing in white and go to normal operation mode.



#### Tip

- If you need to change the choice of the Vigipool "central unit", it is necessary to reset the system (see "Reset").
- 

## 5.2.4. Pump priming

To be able to prime the regulation circuit by running the peristaltic pump, the selection button (A) must be kept pressed for a long time (>10 seconds). After 10 seconds, the RGB LED (C) flashes turquoise and the pump starts running regardless of the flow detector status for a maximum of 30 seconds, as long as the selection button is kept pressed. Once the button is released, the pump returns to its normal state. It is necessary to repeat the operation if a longer priming time is required.

## 5.2.5. Sensor calibration

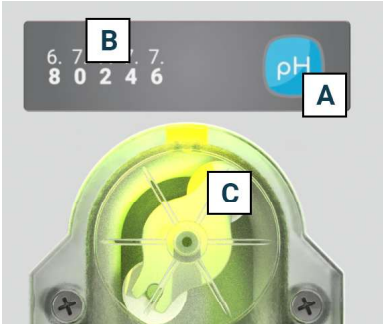

### Tip

Use the supplied pH 6.86 bag and the container to create a calibration solution before proceeding to calibrate. Mix the contents of the bag in 250 ml of water.

1. Immerse the pH sensor in the 6.86 calibration solution
2. Keep the selection button (A) pressed for 3 seconds
3. LED (C) lights blue. Release the selection button (A)
4. The first green LED - 6.8 (B) and LED (C) lights up



### Tip

The 5 green indicators (B) will progressively light to indicate the calibration progress  
The colour of LED (C) will show how far it is from the expected measurement

- Green: measured value very close (+/-0.1)
- Yellow / amber: value off by between 0.1 and 0.5
- Red: measured value is away (deviation of more than 0.5)



### Caution

If the RGB LED (C) flashes red, the calibration is not taken into account: value off by over 0.5 or unstabilised measurement. In that case, the appliance returns to its normal state and troubleshooting can be done on the sensor.

### 5.2.5.1. Sensor calibration using the smartphone app

The smartphone app has more advanced sensor calibration features that guarantee a more reliable and accurate measurement.

- **Calibration using 1 or 2 measurement points:** in addition to the pH 6.86 calibration, you can calibrate using another measurement. A 1-point calibration is also possible using a different value between 6 and 8
- **Manual adjustment:** manual adjustment is used to correct your measurement. For example, if there is a minor drift (+/- 0.5), you can increase or lower your appliance's measurement to be as close as possible to the actual value, in intervals of 0.1.

## 5.2.6. Additional parameters that can be set from the smartphone app:

### 5.2.6.1. Winterisation mode

The app can be used to activate winterisation mode. As long as winterisation mode is active:

- Correction product injection is stopped
- Notifications / alarm messages are disabled
- The RGB LED (C) is permanently lit in cyan

### 5.2.6.2. Maximum daily injection volume configuration

The maximum daily volume of pH corrector to inject can be limited by entering a value different from 0 here. The volume is set to 0.3L by default, even if you are not using the app.

- Volume configurable from 0.1 to 2.0 L
- Incremented in 0.1 L steps

This function and configuration are very important because they protect your pool from excess correction product injections if the sensor gives an incorrect pH value.

For example, a safety set to 0.3 L / 24h is in line with pool volumes of about 60 m<sup>3</sup>. For pool volumes of about 40 m<sup>3</sup>, the value can even be lowered to 0.2 L / 24h.



#### Caution

If this setting is configured to "Disabled"; **no volume injection limits will be applied.**

---

If there is a power failure, the volume injected over the previous 24 hours is reset to 0.

---

### 5.2.6.3. Setting the product volume in the container

Used to indicate the total corrector product container volume. This value is counted down in order to indicate when the container is empty and thus avoid pumping needlessly. This parameter is disabled by default.

The value must be updated every time the container is replaced.

- Volume configurable from 0 to 50 L
- Incremented in 1 L steps

## 6. Appliance operation



### Important

Phileo VP & Phileo POD VP does not take any measurements:

- during the first 2 minutes after power up (time for the value to be set),
  - if the flow rate is not detected by the device (to ensure that measurements are only taken when the filtration is running and to guarantee the correct values of the pool water and not of the stagnant water in the pipe).
- 

### 6.1. Data timer and injection not active:

A hysteresis of  $\pm 0.1$  is provided for to prevent oscillation around the set point value.

Injection may be blocked due to several causes despite a measured value that is different from the set point:

- When the appliance is powered on, there are no injections during the first 2 minutes
- When the flow switch detects a flow, there is a 2 minute delay before injection starts. Injection stops automatically when the flow switches to OFF
- There are no injections if the measurement is  $\text{pH} < 5$  or  $\text{pH} > 9$  (= pH measurement fault)
- There are no injections if the container volume = 0 (injection liquid container empty)

- There are no injections if the 24H Max injected volume is reached
- There are no injections in winterisation mode

## 6.2. Selecting of set-point value

1. Make a quick touch on the selection button (A)
2. One of the 5 green light indicators (B) flashes for 5 seconds displaying the current setpoint.
3. While the LED is flashing, each touch of the selection button (A) moves the setpoint to the right until it is reached 7.6 and then back to 6.8 . Press until the desired setpoint is selected.
4. Wait 5 seconds to validate the setpoint change. The unit will return to the normal mode with the new setpoint.
5. Depending on the selected operating mode, the default value is set to:
  - pH-: 7,2
  - pH+: 7,0

## 6.3. Measured value display

The 5 light indicators on the front display the measured pH (here 7.2). If the pH is between two graduations, the LED for the previous graduation remains steady (here 7.2), the LED below or above it depending on how the pH is read, flashes slowly.

Example on the following images: the measured pH passes from 7.2 to 7.3.

The 7.4 LED will flash, and when the value increases to 7.4 only the 7.4 green LED will be on and steady.



The multi-colour LED (C) on the pump indicates the difference between the measured value and the setpoint:

---

Pump colour - Multi-colours LED (C)	Description
Green	The measured value varies from the setpoint by $\leq 0.1$
Yellow - Orange (gradual*)	The measured value varies from the setpoint by <b>0.1 to 1.0</b>
Red	The measured value varies from the setpoint by $\geq 1.0$

To indicate ongoing injection, the multi-colour LED (C) will flash during this period, while retaining the colour associated with the measurement (e.g. flashing yellow).

\* The lighting on the pump changes colour from green to red as a function of the deviation between the measurement and the setpoint gradually, passing through yellow, orange, etc.

## 7. Reset to zero

It is possible that a factory reset may be required to set the OXEO POD VP & OXEO VP back to the original factory settings.

To do this, please:

1. Turn off the device ( on/off switch on the box side) and wait for about 10 seconds,
2. Press the selection button (A) and maintain the pressure,
3. Turn on the device while holding down the button,
4. Wait until green indicator lights (B) are flashing
5. Release the button. **All parameters are reset to the factory settings.**



### Important

A reset will erase all the parameters in memory (calibration, setpoint, WiFi configuration, bin volume, pairing of phones and other Vigipool Universe devices, etc.). It is therefore necessary to restart the start-up procedure after resetting.

## 8. Sensor maintenance

When a pH or sensor is immersed in water, a film forms around the glass bulb at its tip and gets thicker over time. This invisible film causes response times to lengthen, deteriorates the slope and deviates from point 0. It is easy to compensate for changes to

---

point zero by regularly recalibrating. Increased temperatures are also a major ageing factor.

#### Sensor protection:

Remove the sensor from the pipe and keep it in its original bottle

Fill the original bottle with a KCl solution of 3 mol/litre or, failing that, with a PH7 solution or with tap water.

Place the sensor head in the bottle

Keep it at room temperature.



#### Warning

An incorrectly winterised sensor will have a slower response time and make it harder to calibrate.

---

#### Sensor regeneration:

At the end of winterisation, we recommend immersing the sensor in a 50% PH4, 50% KCl 3 mol/l solution for 12h

#### Calibration:

Each sensor is characterised by its drift and slope. As these characteristics tend to drift with use, calibration must be carried out regularly. Calibration is mandatory in the following cases:

- when installing
- after replacing the sensor
- after every cleaning using a cleaning solution
- after long term storage
- when the measurement results are too far from the expected results.



#### Tip

Note that the average sensor service life varies from 6 to 18 months depending on use. A TAC < 100 mg/l reduces the sensor's service life.

Sensors are fragile consumables that should be checked by a professional.

---

CCEI declares that the product Phileo VP & Phileo POD VP meets the safety and electromagnetic compatibility requirements of European Directives 2014/35/EU and 2014/30/EU EU and the Radio Equipment Directive 2014/53/EU.



Emmanuel Baret

Marseille, on 30/06/2023

Distributor's stamp

*Date of sale:* ..... *Batch N°:* .....