



Oxeo VP

Automatic and Connected Chlorine Regulator

Technical Manual



PF10J055

Table of Contents

- 1. Important Safety Instructions 3
- 2. Package Content 4
- 3. Description 5
- 4. Technical Specifications 5
- 5. Installation 6
 - 5.1. Wall Mounting 7
 - 5.2. Hydraulic Connection 7
 - 5.3. Accessories Positioning (Zelia POD, for 1.5" Piping) 9
 - 5.4. Accessories Positioning (for 2" Piping) 11
 - 5.5. RedOx Sensor, Flow Switch and Tube Connection 13
 - 5.6. Electrical Wiring 13
- 6. Smartphone Application 15
 - 6.1. App Download 15
 - 6.2. Connect your Device to Vigipool 16
- 7. Setting the Oxeo 16
 - 7.1. Control Interface 16
 - 7.2. Getting Started with the Oxeo 17
 - 7.3. Additional Parameters to be set via the Smartphone App (Vigipool) 20
- 8. Operating the Oxeo 21
 - 8.1. Information Delay and Non-Active Injection 21
 - 8.2. Setpoint Selection 22
 - 8.3. Measured Value Display 22
 - 8.4. Product Factory Reset 23
- 9. Sensor Maintenance 24
- 10. Wintering 25

Technical Support / Declaration of Conformity

1. Important Safety Instructions



Caution

When installing and operating this electrical equipment, basic safety precautions should be followed, including the following:

- READ AND FOLLOW ALL INSTRUCTIONS IN THIS MANUAL
- WARNING - To reduce the risk of injury, do not permit children to use this product unless they are closely supervised at all times.
- WARNING - Risk of Electric Shock. Connect only to a branch circuit protected by a ground-fault circuit interrupter (GFCI). Contact a qualified electrician if you cannot verify that the receptacle is protected by a GFCI.
- WARNING - To reduce the risk of electric shock, replace damaged cord immediately.
- SAVE THESE INSTRUCTIONS.



Caution

IMPROPER INSTALLATION OR USE OF THIS PRODUCT CAN CAUSE SERIOUS INJURY OR DEATH.

INSTALLERS, MAINTENANCE PERSONNEL AND THE POOL OWNER MUST READ AND UNDERSTAND THE WARNINGS AND INSTRUCTIONS IN THIS MANUAL BEFORE USING THIS PRODUCT.



Warning

This manual contains instructions for installing and using the Oxeo VP. Contact CCEI for any questions about the equipment.

To the **installer**: This manual contains important safety information on the installation and use of this product. This manual should be given to the user after installation.

To the **user** : This manual contains important information that will help you use this product properly. Please keep it as a reference.



Warning

Always read the Material Safety Data Sheets (MSDS) and instructions related to the storage and use of chemicals used with this controller.

2. Package Content

- 1 x Oxeo VP (P/N: PF10J055)
- 1 x RedOx sensor with 80" of cable (2 m)
- 1 x 650 mV calibration solution
- 1 x Flow switch with 115" of cable (2.9 m)
- 1 x 144" (3.6 m) of injection tube (7/32" OD) + connection accessories
- 1 x MM 3/4" - 3/4" adapter for flow switch
- 2 x screws, 2 x dowels and 1 x bracket for wall mounting of the product
- 1 x Technical manual (this manual)

3. Description

Features

- Automatic regulation of RedOx according to a setpoint
- Dosing pump with a visual status indicator (RGB LED)
- Intuitive interface with 1 selection button and 5 LEDs indicating the pool's RedOx level
- Control with a smartphone app (Vigipool NA)
- Wi-Fi and Bluetooth connection
- Easy installation thanks to the Zelia measuring and injection chamber
- Compatible with the Vigipool-connected universe

Oxeo VP measures the RedOx potential and introduce an oxidizing product into the pool water as long as the RedOx potential is below the set threshold.

All disinfectants used in swimming pools have the function of oxidizing microorganisms. This oxidation, which consists in capturing electrons on organic molecules, prevents the proliferation of bacteria. This chemical reaction is called oxidation-reduction and we can evaluate the capacity of the water to disinfect by measuring its oxidation-reduction potential (RedOx potential or ORP).

The pool water must not only be clean and healthy, but it must also be able to destroy bacteria and microorganisms that are brought in from outside. Therefore, it is not enough to disinfect it, but it must still be made disinfectant. It is therefore essential to use "persistent" products.



Caution

The level of RedOx is an extremely important parameter for the treatment of your pool water and can have toxic effects on health and the environment.

Chemicals must be handled and stored with care and in a suitable environment.

4. Technical Specifications

Size (H x L x W)	5" x 4" x 2.5" (260 x 180 x 80 mm)
Weight	700 g (Oxeo VP only)



Installation	Inside and outside
Voltage of operation	120 VAC @ 0.2 A, 50 / 60 Hz
Rated power	22 VA (max)
Ingress protection rating	IP 54
RedOx measurement	Measurement by combined electrode +/- 5 mV
Measuring range	100 to 900 mV
Calibration	650 mV (provided solution) or between 550 to 750 mV through the app
Dosing pump	Peristaltic
Maximum water flow	Up to 1.5 L / h (0.4 gal / h)
Size of the measuring and injection chamber (Zelia Pod)	3.35" long, installed on 1.5" piping (via union fittings)
Bluetooth	Low Energy (v4.x) Conform R&TTE Directive 1999/5/EC
Wi-Fi	802.11 b/g/n and "dual band" (2.4 GHz only)

5. Installation



Warning

Always mount the controller in a safe and non-floodable area. Never bury the power cable.

The controller must not be installed directly outside, it must be protected from rain, cleaning or watering jets and UVs (sunlight).

The controller is splash-resistant, but should not be placed in a floodable area.

The controller must be placed on a flat and stable surface and fixed to the wall using the supplied plugs and screws.



Warning

For safety reasons and by the NF C15-100 standard, the product must be installed:

- at more than 3.5m from the edge of the pool. This distance is evaluated taking into account obstacles. If the Oxeo is installed behind a wall, it is the distance needed to go around it and reach the box that is taken into account.

- or in an underground room in the immediate vicinity of the pool. In this case, the room must be accessible through a trap door requiring a tool for its opening.



Tip

Prior to installation, verify that the Wi-Fi network is available where the product will be installed.

5.1. Wall Mounting

Using the two screws and two dowels provided, attach the bracket to the wall. The tab should be facing up.

Once the bracket is attached, slide the Oxeo from top to bottom until you hear a "click".

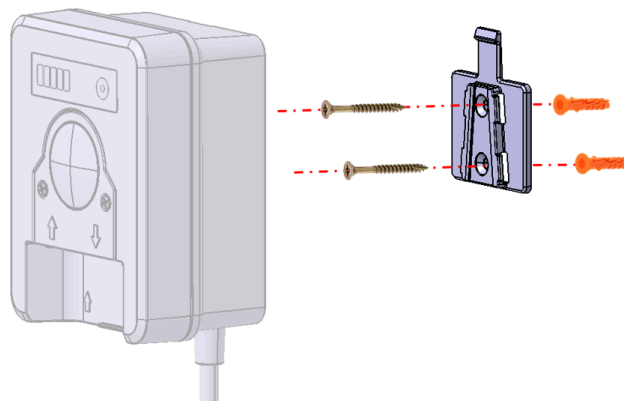

5.2. Hydraulic Connection

1.5" piping: It is preferable to install the Zelia Pod measuring chamber in bypass to control the flow through the measuring chamber and to be able to remove it without interrupting the filter unit. (A bypass installation is essential when the flow rate is greater than 15 m³/h (66 gpm)).

2" piping: Use the 3 support clamps to install the RedOx sensor, the flow sensor and the injector in line on the 2" pipe.

The equipment should be placed after the filtration and the heater, and before a chlorinator, and be positioned on a horizontal pipe always loaded with water. The ORP probe must always be immersed in the water.



Warning

When installing and using the Zelia Pod, make sure that it is loaded relative to the water level of the pool, so that it is constantly filled with water and free of air. If air is present in the measurement chamber, the sensor readings may be distorted.



Caution

The injection of liquid corrector must always be installed after the filter unit and the heater, and before the electrolysis cell! Otherwise, these components could be irreversibly damaged.

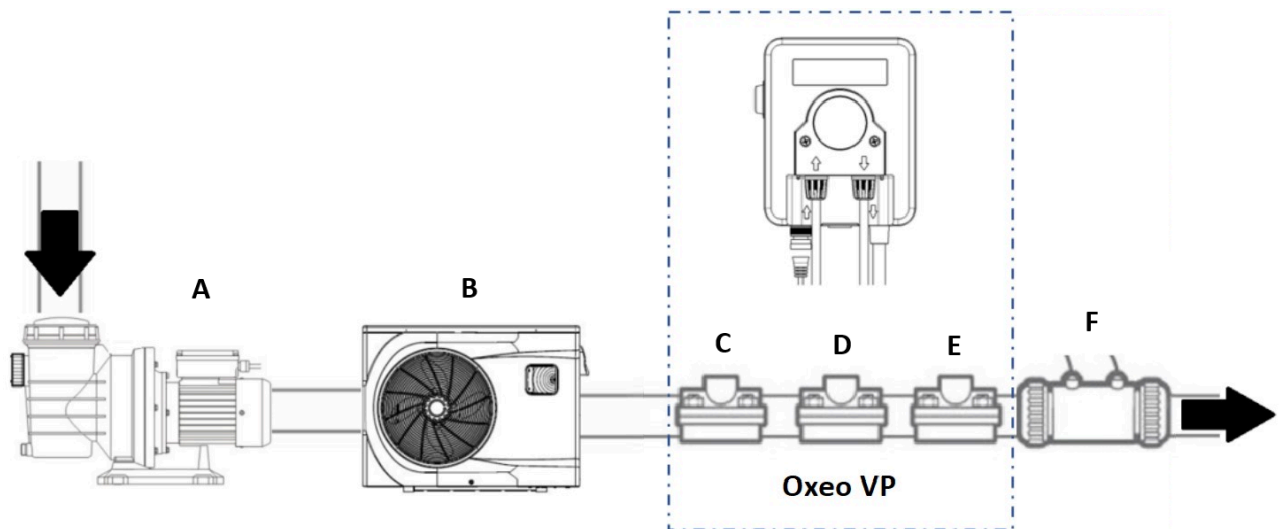

- A: Pump
- B: Heater
- C: Flow switch
- D: ORP probe
- E: Injection tube
- F: Salt chlorine generator (electrolysis cell)

5.3. Accessories Positioning (Zelia POD, for 1.5" Piping)



Warning

Before installing the Zelia POD, disconnect the power supply of the filtration group and drain all the water from the circuit.

1. Installing the Zelia POD

On the 1.5" pipe, cut a 7,8" section (200 mm). Glue the 2 provided union fittings using the appropriate glue.

Position the different elements by referring to the photo below. To screw in the injectors (E or F), use the flat gasket supplied to ensure the tightness of the assembly. It is recommended to use Teflon tape in all the threads.

The water flow is illustrated by the blue arrow in the picture below:



- A: Pool Grounding (Allows you to put the water to the ground to improve the durability of the metallic parts in your pool)
- B: Housing for sensor (not used)
- C: Housing for sensor (via provided cable gland)
- D: Flow sensor (when installing, make sure that the arrow on the flow sensor points in the same direction as the flow direction)

- E: Housing for injection (not used)
- F: Housing for sanitizer injection

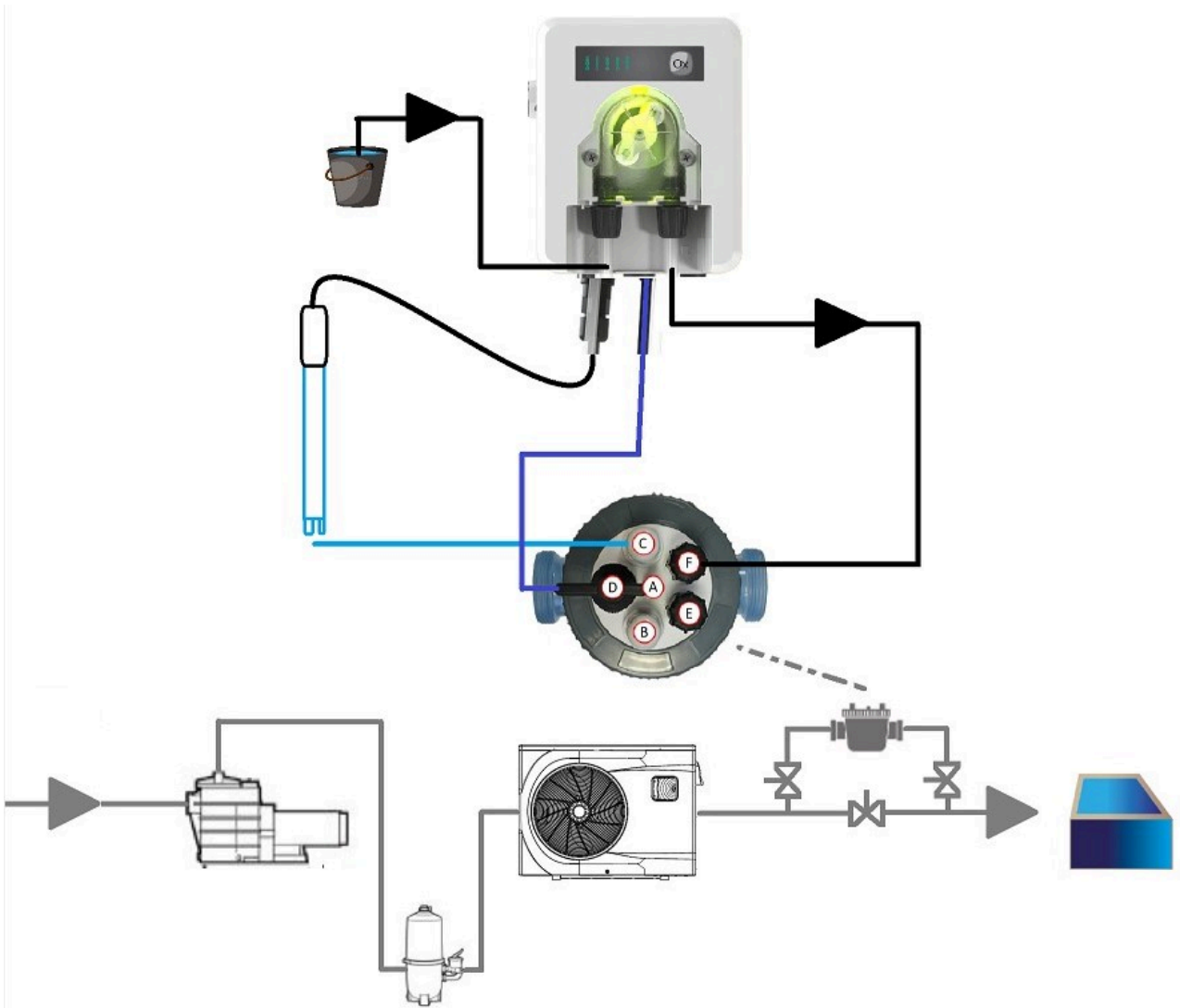

2. RedOx sensor installation:

Open the RedOx probe box and remove the storage solution. Carefully place the probe in the slot (B or C). When the probe touches the bottom of the slot, pull it out 3-4 mm so that water can flow around it. Tighten the gland nut.

3. Injector installation:

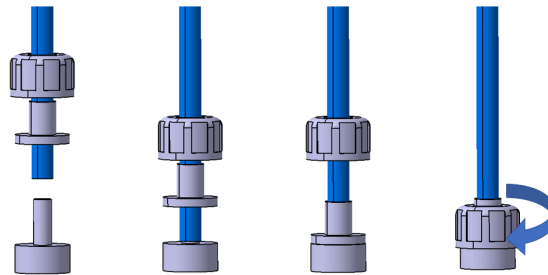

Remove the upper part of the injector and mount the threaded part in the slot (E or F) of the Zelia Pod

Place the cap and top ring around the flexible tube.

Push the tube into the injector.

Screw the two pieces on the tube of the lower part of the injector.

4. Flow switch installation:

Screw the flow sensor onto the location (D) and validate that the arrow is in the direction of the flow.

5.4. Accessories Positioning (for 2" Piping)

Using the supplied support clamps, mount the RedOx probe, injector and flow sensor.



Warning

Do not mount the disinfectant injection before the probe! (The sensor measurement would be distorted)

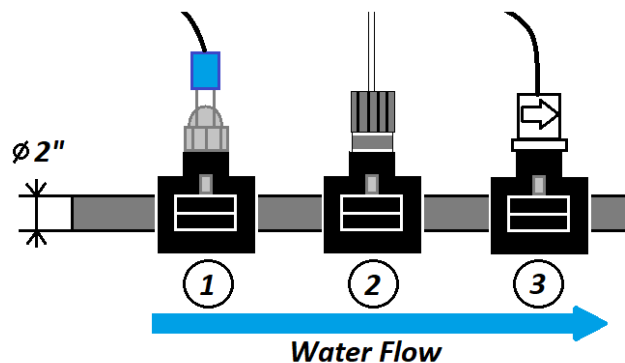

Before installation, water must be drained from the piping. For each location, drill a hole in the top of the pipe between 11/16" and 7/8" (18 - 22 mm) in diameter.

1	Support clamp with 1/2" thread: mount the supplied gland using Teflon tape. Insert the RedOx probe carefully, until it reaches the bottom of the pipe. Remove the probe by 3-4 mm.
2	Support clamp with 1/2" thread: mount the injector using Teflon tape. Use the tube provided and connect it to the Oxeo (right side). Refer to the image below for more details on the assembly.
3	Support Clamp with 3/4" thread: Put Teflon on both sides of the 3/4" male-to-male adapter. Screw the adapter into the support clamp, then screw the flow sensor onto it. Caution, an arrow indicating the direction of flow is present on the flow sensor, the arrow must be pointed in the direction of flow.

Tubing installation on the disinfectant injector (#2):

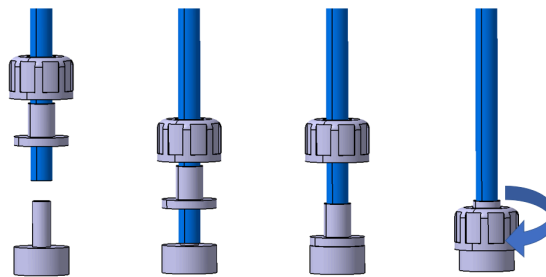

- Put the threaded cap and the pressure washer around the tube
- Insert the nozzle into the tube as far as it can go
- Insert the injection washer and screw on the nut

5.5. RedOx Sensor, Flow Switch and Tube Connection

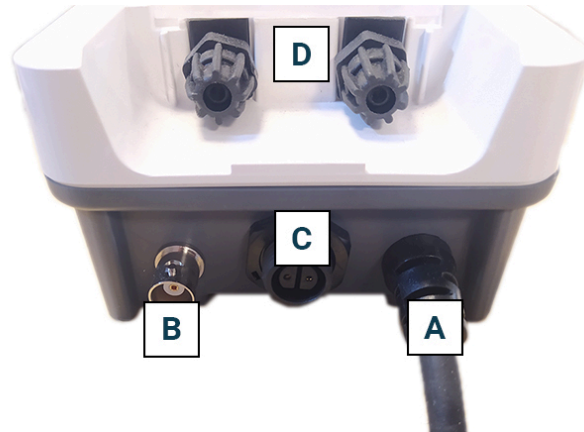

A: Power supply cable (120 VAC)

B: BNC socket for the RedOx sensor installation

C: Flow switch connector

D: Dosing pump



Warning

For (D): the adapter on the left is for the aspiration of the disinfectant, and the one on the right is for the injection of the product into the pool water

5.6. Electrical Wiring



Warning

Risk of electric shock. Connect the controller only to a grounded outlet protected by a ground fault circuit interrupter (GFCI). We recommend installation to a dedicated GFCI. Installation should be performed by a licensed electrician.

Disconnect power before servicing. There are no user-serviceable parts inside the controller.

All power cords should be inspected frequently. Any damaged power cords should be replaced immediately to reduce the risk of electric shock. Never operate a controller without a working flow switch.

Installation requires a properly located GFCI-protected outlet. Never use an extension cord for electrical connections to the controller.



Caution

The unit is equipped with a flow sensor and should not be installed on a power supply that is connected to the filtration system. This may cause the unit to malfunction.

The box is delivered with a power cable that can be connected to the mains on a standard plug (120V, 50 / 60 Hz) in the technical room. This socket must be protected by a 30mA differential device (GFCI) by the NFC15-100 standard.

6. Smartphone Application

6.1. App Download

Search for Vigipool NA in the search engine of the App Store or Play Store and install the app on your device. You can also use the following QR code:

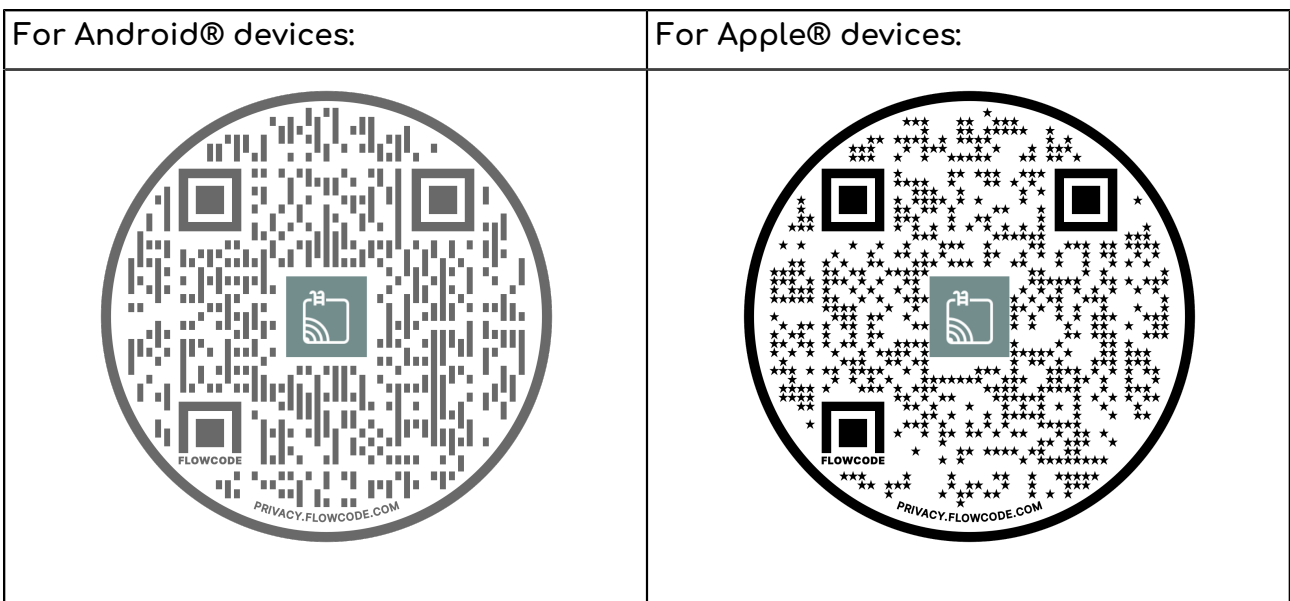

The Oxeo VP includes a Bluetooth® and Wi-Fi transmitter, which allows your device to be controlled by a smartphone or tablet. To control the Oxeo, an iOS (Apple®) or Android® device with a Bluetooth® Low Energy (v4.x) OR WiFi 502.11 B:N:G connection is required. Other operating systems (Windows Phone®,...) or devices equipped with a previous version of Bluetooth® - lower than 4.0 - are not compatible.

In Bluetooth, only one mobile/tablet can be connected at any time. To connect to a new device, the previous one must be disconnected.

In Wi-Fi, a Vigipool account must be created in the application, and the ID and SSID of your Wi-Fi network must be entered.



Tip

Bluetooth and geolocation of your phone must be enabled when connecting for the first time and when using the product in Wi-Fi

If the device is connected via Wi-Fi (recommended), multiple devices can be connected to the product at the same time and can be controlled from anywhere.

6.2. Connect your Device to Vigipool

With Vigipool, all Vigipool-compatible products can be controlled with a single application.

To connect this product to the Vigipool app:

- If no other Vigipool product is connected and the Oxeo is the only one when the product is first powered on, wait for the LED to flash WHITE. Press the "Ox" button on the product to make the Oxeo the "Central" of the environment. When other Vigipool-compatible products are added to the environment, they will automatically pair up with the "Central" product, provided that the "Central" product has been restarted at least 1 minute before the operation.
- If another Vigipool product is already connected, turn off all Vigipool products and start them at the same time. The new products will be paired directly with the current "Central".



Tip

If you have a CCEI Tild, this product will always be defined as "Central".

7. Setting the Oxeo

The Oxeo VP can be set up via the interface of the box or via the smartphone app available on iOS® and Android®. We encourage you to use the app, which gives access to additional settings, especially for sensor calibration.

7.1. Control Interface

The interface is equipped with a button (A), 5 indication LEDs (B) and an RGB LED (C) installed behind the dosing pump.

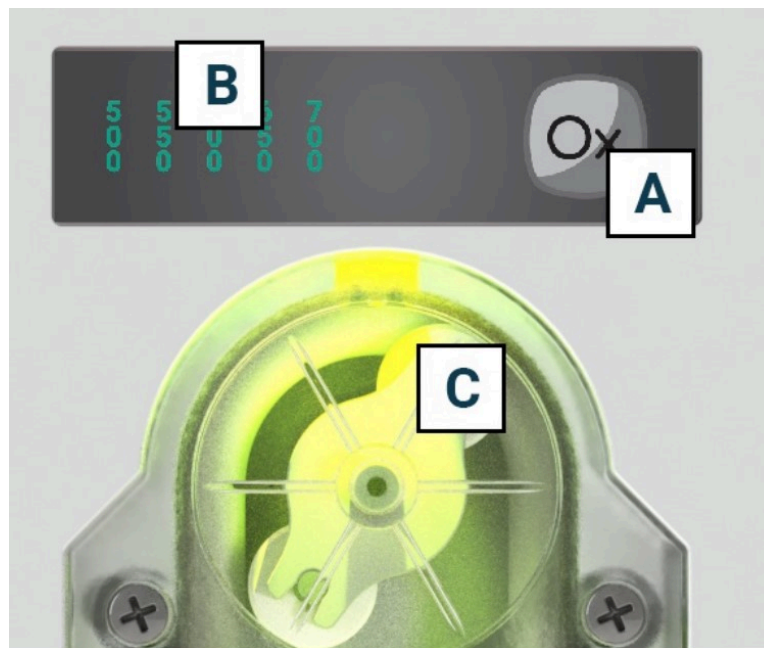

7.2. Getting Started with the Oxeo

7.2.1. Powering Up

The system is activated by the switch on the side of the automatic controller.

At startup, the front panel lights will flash for several seconds while the unit is being turned on.

[Initialization phase: chase on the green light indicators (B) then different colours of the multi-color LED (C)]

7.2.2. Vigipool "Central" Device Selection

At the end of the initialization phase, the multi-color LED (C) flashes white. This corresponds to the choice of the device that will perform the Vigipool "Central" function:

- If the system has only this device, press the selection button (A). The device is now configured as a Vigipool "Central" and you can add other devices to the system later.
- If the installation is equipped with several Vigipool Universe-compatible devices:
 - And that a device is already configured as Vigipool "Central", restart the Vigipool "Central" device if it has been powered for more than one minute. Your Oxeo VP

will connect to the Vigipool "Central": it will stop flashing in white and go to normal operation mode.

- And that no other device is already configured as Vigipool "Central", turn on all the devices and press the button of the device you want to use as Vigipool "Central". The other products will then connect to the device you have validated as Vigipool "Central", stop flashing in white and go to normal operation mode.



Tip

If you want to change the choice of the Vigipool "Central", it is necessary to reset the system (see the section "Product Factory Reset")

7.2.3. Pump Priming

To start the control circuit by rotating the peristaltic pump, it is necessary to hold down the selection button (A) for a long time (more than 10 seconds). After 10 seconds, the multi-color LED (C) will flash Turquoise and the pump will rotate regardless of the status of the flow sensor, for a maximum of 30 seconds, as long as the selector button is held down. Once the button is released, the pump will return to its normal state. It is necessary to repeat the operation if a longer priming time is required.

7.2.4. RedOx Sensor Calibration

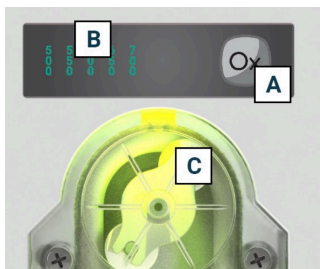

Tip

Filtration must be turned off to calibrate the sensor.

1. Immerse the probe in the 650 mV calibration solution
2. Press and hold the selection button (A) for 3 seconds
3. The RGB LED (C) lights up blue. Release the selection button (A)
4. The first green indicator (B) - 500 mV and the multi-color LED (C) light up



Tip

The 5 LEDs (B) will progressively light up to indicate the progress of the calibration.

The colour of the RGB LED (C) lights up depending on the difference compared to the expected measurement:

- Green: very small deviation between the measured and expected values (deviation less than 50 mV).
 - Yellow / Orange: small deviation between the measured and expected values (deviation between 50 and 150 mV).
 - Red: big deviation between the measured and expected values (deviation greater than 150 mV)
-

1. Once the 5 LEDs (B) are lit and fixed, and the RGB LED (B) is lit in green or yellow, the measurement is stabilized.
2. Press the selection button to confirm the calibration.
3. The RGB LED flashes rapidly in green to indicate the validation of the calibration.
4. The first green indicator (B) - 500 mV and the multi-color LED (C) light up



Caution

If the RGB LED flashes red, the calibration is not taken into account: the value has a deviation greater than 150 mV or the measurement has not stabilized. In this case, the device returns to its normal state and a diagnosis can be made on the sensor.

7.2.5. RedOx Sensor Calibration via the App

The smartphone app offers more advanced features to calibrate the probe to ensure a more reliable and accurate measurement.

- **Calibration with one measuring point:** Instead of calibrating at 650 mV, you can calibrate with another value between 550 and 750 mV.
- **Manual adjustment:** The manual adjustment allows you to correct your measurement. For example, in case of a slight deviation (up to +/- 200 mV), you can increase or decrease the measurement of your device as close as possible to the real value, by increments of 20 mV.

7.3. Additional Parameters to be set via the Smartphone App (Vigipool)

7.3.1. Wintering Mode

The application allows you to activate the wintering mode. As long as the wintering mode is activated:

- The injection is stopped.
- Notifications and alerts are disabled.
- The RGB LED (C) is lit in cyan, continuously

7.3.2. Main Power Frequency Setting

Since the operating frequency of the power supply may vary depending on the region of use, it is possible to indicate in the application whether the frequency is 50 or 60 Hz.

The power supply frequency is set to 60 Hz by default.



Warning

The frequency of the main feed affects the pump speed rotation, thus the volume of correction fluid injected. If this parameter is incorrectly set, the Oxeo will indicate a wrong daily injection volume and a wrong volume of product remaining in the container.

7.3.3. Maximum Daily Injection Volume Setting

The maximum daily volume of RedOx corrector to be injected can be limited by setting a non-zero value. The default volume is 1.0 L (even when not set in the application).

- Daily volume adjustable from 0.1 to 2.0 L
- Increment of 0.1 L at a time

This function and setting are very important because it protects your pool from too much product injection in case the sensor gives an incorrect value.



Caution

In case this parameter is set to "Off", no limitation of the injected volume will take place.

In case of a power failure, the volume injected during the last 24 hours is reset to 0.

7.3.4. Adjustment of Product Volume in the Container

This function allows you to indicate the total volume of the correction product container. This value is counted down to warn you when the tank is empty and avoid unnecessary pumping. By default, this parameter is not activated. The value must be adjusted each time the container is replaced.

- Volume adjustable from 0 to 50 L
- Increment of 1 L at a time

8. Operating the Oxeo



Warning

Oxeo VP does not perform measurements:

- during the first 2 minutes after powering up (to wait for the stabilization of the measurement),
 - when the flow rate is not detected by the device (to take measurements only when the filtration is on and thus be sure to measure the water in the pool and not the water stagnating in the pipe).
-

8.1. Information Delay and Non-Active Injection

A hysteresis of ± 50 mV is provided to avoid oscillation around the set value.

Several causes can lead to a non-active injection despite a measurement different from the set point:

- When the device is started, no injection occurs in the first 2 minutes because the device does not yet measure the ORP value.
- When the flow meter detects a flow rate, a 2-minute delay is built in before injection. The injection is instantly stopped when the flow rate returns to OFF.
- No injection if ORP measurement is lower than 100 mV (RGB LED in red and the 5 green lights on) or greater than 900 mV (RGB LED in Magenta and the 5 green lights on) => ORP measurement fault.

- No injection if tank volume = 0 (empty liquid disinfectant tank).
- No injection if the Max 24h injection volume is reached (RGB LED blinking in orange).
- No injection in wintering mode.

8.2. Setpoint Selection

1. Short press the selection button (A).
2. One of the 5 green indicators (B) flashes for 5 seconds indicating the current setpoint.
3. While the LED is flashing, each press of the selection button (A) shifts the setpoint to the right until it reaches 700 mV and then back to 500 mV. Press until the desired setpoint is reached.
4. Wait 5 seconds to validate the change of setpoint. The unit returns to its normal mode with the new setpoint.
5. By default, the setpoint is set to 600 mV.

8.3. Measured Value Display

The 5 indicator LEDs on the front panel display the measured ORP value (here 600mV). If the ORP is between two graduations, the LED of the previous graduation remains fixed (here 600mV), and the LED below or above, depending on the reading direction of the ORP, flashes slowly.

Example in the following pictures: the measured ORP increases from 600 to 630 mV.

LED 600 will flash and when the ORP value increases to 650 mV, only the green LED 650 will be permanently lit.

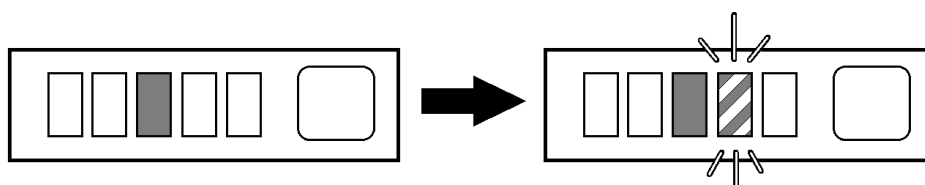

The RGB LED on the pump indicates the deviation between the measured value and the setpoint:

LED Colour	Description
Green	The difference between the measured value and the setpoint is less than or equal to 50 mV.
Yellow - Orange (gradual*)	The difference between the measured value and the setpoint is between 50 and 150 mV.
Red	The difference between the measured value and the setpoint is greater than or equal to 150 mV.

To indicate that the injection is in progress, the multi-color LED (C) will flash during this period, while maintaining the colour associated with the measurement (e.g. flashing yellow).

* The colour of the pump light changes from green to red depending on the deviation of the measurement from the setpoint, gradually passing through yellow, orange, ...

8.4. Product Factory Reset

If you install a new Vigipool-compatible product and wish to change the "Central" device, or for any other reason, a factory reset is available as follows:

- Turn off the unit (switch on the side of the enclosure) and wait approximately 10 seconds;
- Press and hold the selection button (A);
- Turn on the device while holding down the button;
- Wait for the green indicator lights (B) to flash;
- Release the button. All the parameters are reset to the factory settings.



Warning

Performing a product reset will erase all the parameters in memory (calibration, setpoint, WiFi configuration, tank volume, pairing of telephones and other devices in the Vigipool Universe, etc.). Therefore, it is necessary to redo the commissioning procedure after resetting the product.

9. Sensor Maintenance

When a probe is immersed in water, a film forms around the glass bulb at the end of the probe, the thickness of which increases with time. This invisible film induces a longer response time, a degradation of the gradient and a drift of the 0 point. The drift of the 0 point can be easily compensated by a regular calibration. The increase in temperature is also an important factor in aging.

Probe storage:

Remove the probe from the pipe and store it in its original bottle.

Fill the original vial with a 3 mol/L KCl solution or with a PH7 solution or tap water.

Place the probe head in the bottle.

Store at room temperature.



Warning

A poorly wintered probe may have a slower response and thus make calibration more difficult.

Probe regeneration:

At the end of wintering, it is recommended to immerse the probe for 12 hours in a 50% PH4, 50% KCl solution at 3 mol/L.

Calibration:

Each probe is characterized by its drift and gradient. Since these characteristics tend to drift with use, regular calibration is necessary. Calibration is mandatory in the following cases:

- During installation.
- After a probe replacement.
- After each cleaning with a cleaning solution.
- After a long storage period.
- When the measurement results differ too much from the expected values.

Tip

Note that the average probe lifetime varies between 6 and 18 months depending on usage. A TAC greater than 100 mg/L reduces the life of the probe.

The probes are fragile consumables that must be inspected by a professional.

10. Wintering

If your pool or spa is winterized, it is necessary to remove the RedOx sensor from the installation and store it properly. See **Section 9. Sensor Maintenance** for probe storage procedure.

Warning

Not doing this operation can damage the RedOx sensor.

If, during the winter, the ambient temperature may fall below 0°C or 32°F, it is necessary to store the Oxeo VP and injection tubes in a frost-free location.

Warning

WARNING: Care must be taken when handling equipment or accessories containing acid. Wear loose clothing, waterproof gloves and safety goggles when handling products containing acid.

If the acid freezes, it will expand, risking damaging the Oxeo and injection hoses.

USA: na.ccei-pool.com/us/ Tel: +1 424 800 2191

Canada: na.ccei-pool.com/ca/ Tel: +1 514 963 4226

Mexico: na.ccei-pool.com/mx/ Tel : +52 442 688 7199

CCEI Inc. (Quebec 1170122155) declares that the Oxeo VP is compliant with the safety and electromagnetic compatibility requirements. The product Oxeo VP is UL certified in the file E524688



Pierre-Yves Flattot
Montreal, on 3/23/2026

Distributor's stamp

Date of sale: Lot N°: